



Alpha Power α Power Series Busway



Leading The Future of Electrification

- A Global Heritage Brand with 130 Years of Product Innovation
- Perfect Products, Creative Services, and Competitive Price

Since 1886, Westinghouse Has Brought The Best To Life.

Westinghouse remains a trusted name globally in consumer and industrial products. Built on a heritage of innovation and entrepreneurial spirit, Westinghouse products were the first to supply the United States with AC electric power, transmit a commercial radio broadcast and capture man's first step on the moon. Today, Westinghouse continues to grow its diverse portfolio with a wide range of product categories that include home appliances, consumer electronics, lighting and power generation.

Scope of business | Manufacturing & distribution of electrical products for industrial and household application.

Main Products

- | | |
|-----------------------------------|---------------------|
| MCB | MCCB |
| Vacuum Circuit-breaker | AVB |
| Medium and low voltage switchgear | Transformer |
| High and low voltage busway | Capacitor & Reactor |



Table of content

Corporation Profile

Product Introduction

Product Feature.....	01
Standard.....	04

Electric Parameter

Short-circuit ratings.....	05
Resistance, reactance, impedance and voltage drop.....	06

Dimension

Straight length.....	08
Plug-in straight length.....	09
Flanged end.....	14
Flanged end cut out and drilling pattern.....	15
Flanged end bar hole pattern.....	16
Expansion joint.....	17
Reducer.....	17
Transposition joint.....	17
Terminal cover.....	17
Tap-off units.....	18
End tap box.....	19
Flanged end with end tap box connection.....	20

Installation

Protection Class.....	20
Minimum clearance required for installation.....	20
Minimum clearance required for plug-in box installation.....	20
Horizontal wall-through installation.....	21
Horizontal installation-trapeze hangers Overhead Support..	21
Horizontal installation-wall support.....	22
Vertical installation.....	23
Installation for Vertical Spring Hanger.....	23
Installation for Vertical Fixed Hanger.....	24

Product Code

Product Introduction

Product Feature



Aluminum alloy housing

- Alpha Power busway adopts two-pieces aluminum alloy housing, which is light in weight and high in mechanical strength; effectively avoids the influence of eddy current and hysteresis loss, suitable for various application.
 - The all-aluminum housing has excellent electrical conductivity, providing much higher grounding capacity than the copper/aluminum bar (50% of the phase bar).
 - The unique “serrated surface” design of extruded aluminum housing greatly improves the heat dissipation for the whole busway system.
- Special surface treatment helps the housing to withstand 2000-hour of salt spray test;
- The Alpha Power busway provides more reliable IP protection than the traditional design.

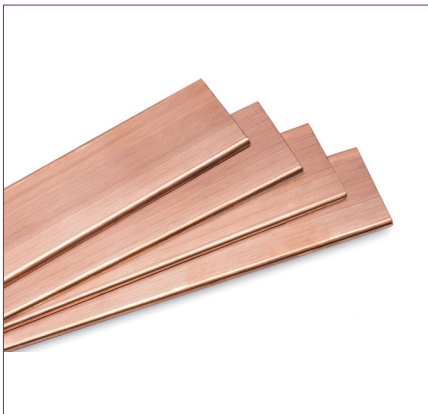

Conductor

- High-speed sawing machine offers a high sawing accuracy, make smooth cut without issues like deformed, stretched, inconsistent flat end, as a result the temperature rise at the busway joint is decreased.
- The bus bar adopts high quality of copper and aluminum conductor with less power losses by 3~5%.
- The high purity conductors are treated by unique technique, the composition of the trace element being under control. The treatment process in tin plating (silver as option) also gives the benefit of much lower contact resistance.



Tap off unit

- A mechanical interlocking between the specialized pin lock mechanism and the box to prevent the plug box from being inserted and extracted with load, effectively ensuring the safety and reliability of power operation.
- The pins are made of high-quality shaped copper molded at one time. Sample testing with insertion and extraction will be made for the pins to ensure the permanent clamping force after power-on, ensuring the reliable operation of the tap off unit.

Unique joint design & Temperature rise indicator

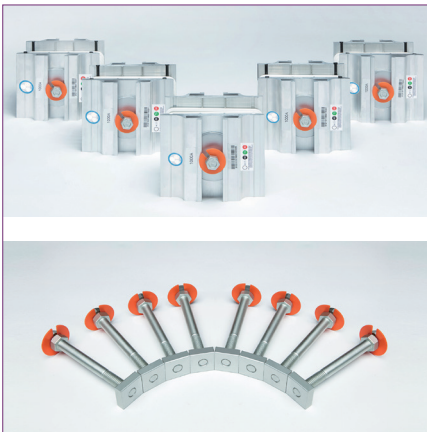

- Joint insulator with a convex-concave groove edge provides an increased creepage distance.
- Color-coded-temperature indicator applied at busway joint is to give an early warning when high temperature occurs at the joint.
- Single bolt joint design is applied to shorten the time of connection by 50% than the traditional design.
- Double headed "break off" joint bolt is applied to tighten the busway with just a common 16mm socket wrench. Belleville spring washers are adopted to ensure pressure evenly applied across the joint.

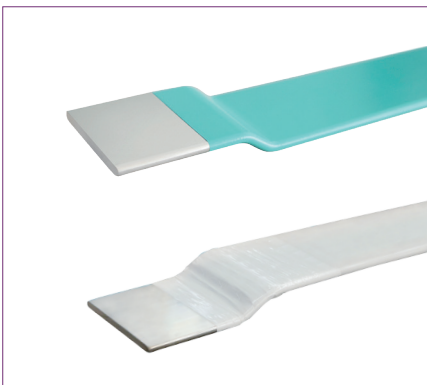

Superior & Reliable insulation

- Both polyester film insulation and epoxy insulation (Class B) are available with exceptional electrical performance and superior mechanical strength.
- Environmental friendly materials are applied with certification by reputed international laboratory. The busway system is halogen-free with no toxicity emission in case of fire.



Compact outlet

- No bending at the outlet, and the busway is full-length compact. Low impedance, which makes lower voltage drop and less line loss of the busway system.
- Fast heat dissipation and large tapping capacity make the tapping current more safe and reliable.

With proper structure, attractive appearance and the high protection class.

Product Introduction

Product Feature

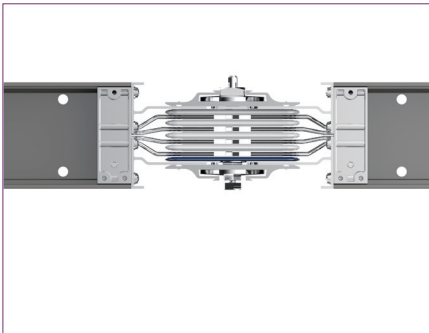

Proof for wrong-phase

- A unique error-proof device is designed to prevent potential damage on bus bar due to incorrect connection. With this unique device, the installers can not connect two sections of busway successfully with incorrect phase orientation. Bridge type joint, each joint allow $\pm 8\text{mm}$ liner adjustment.



"Sandwich" conductor structure

- The conductors are arranged densely in the housing, achieving the performance of superior heat dissipation, lower temperature rise and elimination of "chimney effect". Current-carrying capability is not affected by different installation sites or methods. This compact structure has a width of only 125mm, occupying smaller building space.

Standard

W Power busway conforms to the following standards:

- IEC 61439-1:2011
- IEC 61439-6:2012
- IEC 60529-1:2001



Electric Parameter

Short-circuit ratings

The ratings shown below are UL recognized rms symmetrical amps. Tests were run per UL 857 standards.

The system can comply with IEC61439 for short circuit withstand test at 1 Second.

Rated short circuit withstand current

Copper	(RMS Symmetrical, KA)
Current	1 Sec.
400A	30
630A	30
800A	50
1000A	50
1250A	50
1600A	65
2000A	65
2500A	65
3200A	120
4000A	120
5000A	120

Rated short circuit withstand current

Aluminum	(RMS Symmetrical, KA)
Current	1 Sec.
250A	30
400A	30
630A	30
800A	30
1000A	50
1250A	50
1600A	65
2000A	80
2500A	80
3200A	120
4000A	120

Resistance, reactance, impedance and voltage drop

Copper conductor:Frequency-50Hz

Current	Resistance R_{20} (mΩ/m)	Resistance $R_{Full\ Load}$ (mΩ/m)	Resistance X (mΩ/m)	Voltage Drop per Meter at Full Load Condition (V/m)				
				Power factor $\cos\phi$				
				0.6	0.7	0.8	0.9	1
400	0.126	0.102	0.041	0.075	0.081	0.087	0.091	0.087
630	0.112	0.090	0.037	0.106	0.114	0.122	0.128	0.122
800	0.077	0.066	0.032	0.099	0.106	0.112	0.115	0.107
1000	0.071	0.055	0.026	0.110	0.118	0.125	0.130	0.123
1250	0.050	0.040	0.019	0.098	0.105	0.111	0.115	0.108
1600	0.034	0.029	0.015	0.090	0.096	0.100	0.103	0.094
2000	0.028	0.023	0.012	0.091	0.098	0.103	0.105	0.097
2500	0.022	0.017	0.011	0.095	0.101	0.105	0.106	0.095
3200	0.024	0.015	0.006	0.106	0.117	0.126	0.134	0.133
4000	0.015	0.011	0.003	0.079	0.088	0.096	0.103	0.104
5000	0.011	0.009	0.002	0.071	0.079	0.087	0.093	0.095

In the table above, the load distribution coefficient $k=1$. In specific project, the k value varies with the branch number of the BTS.

Aluminium conductor:Frequency-50Hz

Current	Resistance R_{20} (mΩ/m)	Resistance $R_{Full\ Load}$ (mΩ/m)	Resistance X (mΩ/m)	Voltage Drop per Meter at Full Load Condition (V/m)				
				Power factor $\cos\phi$				
				0.6	0.7	0.8	0.9	1
250	0.185	0.151	0.073	0.073	0.079	0.083	0.086	0.080
400	0.155	0.121	0.061	0.098	0.105	0.111	0.115	0.107
630	0.120	0.093	0.052	0.124	0.132	0.139	0.143	0.131
800	0.105	0.077	0.027	0.117	0.129	0.139	0.147	0.145
1000	0.072	0.058	0.046	0.139	0.144	0.148	0.147	0.125
1250	0.061	0.044	0.012	0.100	0.111	0.121	0.130	0.132
1600	0.046	0.032	0.015	0.110	0.119	0.127	0.133	0.127
2000	0.041	0.029	0.019	0.138	0.146	0.153	0.157	0.142
2500	0.029	0.022	0.010	0.110	0.119	0.126	0.132	0.126
3200	0.023	0.016	0.007	0.108	0.117	0.125	0.132	0.127
4000	0.015	0.013	0.005	0.090	0.097	0.104	0.109	0.104

In the table above, the load distribution coefficient $k=1$. In specific project, the k value varies with the branch number of the BTS.

Electric Parameter

Resistance, reactance, impedance and voltage drop

Copper conductor:Frequency-60Hz

Current	Resistance R_{20} (mΩ/m)	Resistance $R_{Full\ Load}$ (mΩ/m)	Resistance X (mΩ/m)	Voltage Drop per Meter at Full Load Condition (V /m)				
				Power factor $\cos\phi$				
				0.6	0.7	0.8	0.9	1
400	0.126	0.102	0.049	0.080	0.085	0.090	0.093	0.087
630	0.112	0.090	0.045	0.112	0.120	0.127	0.131	0.122
800	0.077	0.066	0.039	0.107	0.113	0.117	0.119	0.107
1000	0.071	0.055	0.031	0.117	0.125	0.131	0.134	0.123
1250	0.050	0.040	0.023	0.105	0.111	0.116	0.119	0.108
1600	0.034	0.029	0.018	0.097	0.102	0.105	0.107	0.094
2000	0.028	0.023	0.014	0.098	0.104	0.108	0.109	0.097
2500	0.022	0.017	0.013	0.103	0.108	0.111	0.111	0.095
3200	0.024	0.015	0.007	0.112	0.122	0.130	0.137	0.133
4000	0.013	0.010	0.007	0.093	0.098	0.101	0.102	0.090
5000	0.010	0.008	0.004	0.080	0.085	0.090	0.093	0.087

In the table above, the load distribution coefficient $k=1$. In specific project, the k value varies with the branch number of the BTS.

Aluminium conductor:Frequency-60Hz

Current	Resistance R_{20} (mΩ/m)	Resistance $R_{Full\ Load}$ (mΩ/m)	Resistance X (mΩ/m)	Voltage Drop per Meter at Full Load Condition (V /m)				
				Power factor $\cos\phi$				
				0.6	0.7	0.8	0.9	1
250	0.185	0.151	0.088	0.079	0.083	0.087	0.089	0.080
400	0.155	0.121	0.073	0.105	0.111	0.116	0.119	0.107
630	0.120	0.093	0.063	0.133	0.140	0.146	0.148	0.131
800	0.105	0.077	0.033	0.123	0.134	0.143	0.151	0.145
1000	0.072	0.058	0.055	0.152	0.156	0.157	0.154	0.125
1250	0.061	0.044	0.014	0.104	0.115	0.124	0.133	0.132
1600	0.046	0.032	0.018	0.117	0.125	0.132	0.137	0.127
2000	0.041	0.029	0.023	0.149	0.156	0.161	0.162	0.142
2500	0.029	0.022	0.012	0.117	0.125	0.132	0.136	0.126
3200	0.023	0.016	0.008	0.114	0.123	0.130	0.135	0.127
4000	0.015	0.013	0.006	0.096	0.103	0.108	0.112	0.104

In the table above, the load distribution coefficient $k=1$. In specific project, the k value varies with the branch number of the BTS.

Dimension

Straight length

Feeder, the straight length without outlets, can be installed either horizontally or vertically.

The standard length is either 3000mm or 4000mm.

The minimum length is 460mm.

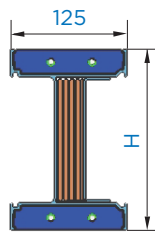

Single-deck
W Power-04~ 25

01

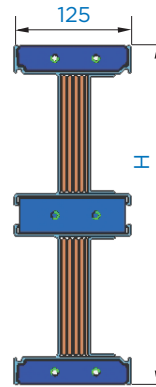

Dual-deck
W Power-32 ~ 50

02

Copper conductor

Current	Dimension		Weight per meter (kg/m)		Fig.
	Width (W)	Height (H)	4wire 100%N	5wire 100%N, 50%PE	
400	125	103	11.3	12.4	01
630	125	103	12.5	13.6	
800	125	118	15.4	17.1	
1000	125	128	18.1	19.9	
1250	125	153	22.8	25.4	
1600	125	188	30.7	34.3	
2000	125	223	38.2	42.8	
2500	125	273	52.8	59.4	
3200	125	352	59.5	66.5	
4000	125	432	76.9	86.3	
5000	125	532	97.3	108.9	

Aluminium conductor

Current	Dimension		Weight per meter (kg/m)		Fig.	
	Width (W)	Height (H)	4wire 100%N	5wire 100%N, 50%PE		
250	125	103	6.8	7.2	01	
400	125	113	7.5	7.9		
630	125	128	8.8	9.3		
800	125	143	9.8	10.4		
1000	125	168	11.8	12.7		
1250	125	203	14.6	15.7		
1600	125	253	18.3	19.8		
2000	125	322	22.6	24.3		02
2500	125	392	28.7	31		
3200	125	492	36.2	39.4		
4000	125	572	44.7	48.9		

Dimension

Plug-in straight length



The plug-in busway has a flexible design with optional plug outlets on both sides. A maximum of 5 outlets can be fixed on each side of 3m standard length. The customer may reserve plug outlets for extension in the future when changes occur in terms of the equipment load or busway run. Both base plate and socket cover are set for each plug outlet. Base plate helps to prevent fingers from contacting live conductors (IP2X) by accident, on which the phase sequences of conductors are identified. Socket cover prevents the conductive contacting surface from being contaminated. A pad may be used to keep off dust or moisture.

Standard length is 3000mm or 4000mm. The minimum length is 720mm. The minimum length of L1 (distance from the center of plug outlet to standard end) is 360mm. The minimum length of L2 (distance between the centers of two adjacent plug outlets) is 570mm.

Dimension

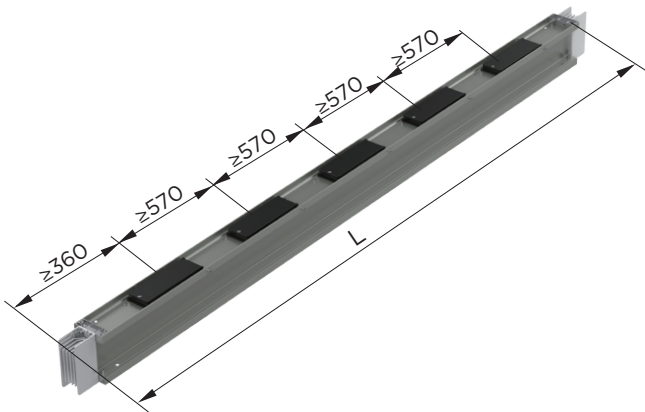

L1=0.36

L2=0.93

L3=1.50

L4=2.07

L5=2.64

Standard length:

Alpha Power C: L=1、2、3m Alpha Power A: L=1、2、3m

Optional length:

Alpha Power C: L=0.72 ~ 4m Alpha Power A: L=0.72 ~ 4m

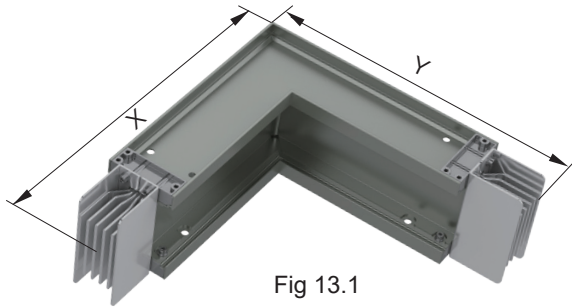

Fig 13.1

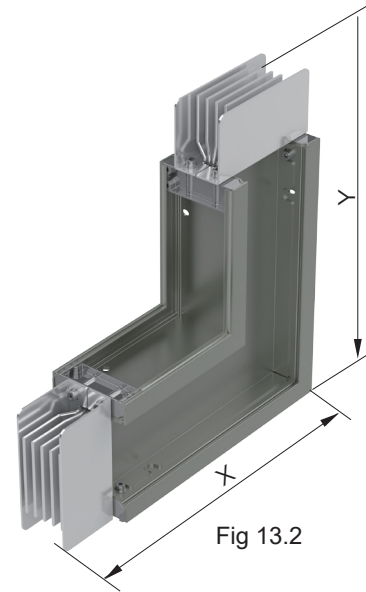

Fig 13.2

L flatwise elbow Fig 13.1

Rated current (A)	Copper busway size (mm)				Aluminium busway size (mm)			
	Minimum		Standard		Minimum		Standard	
	X	Y	X	Y	X	Y	X	Y
250	/	/	/	/	341	341	450	450
400	341	341	400	400	351	351	450	450
630	341	341	400	400	366	366	450	450
800	351	351	400	400	381	381	450	450
1000	366	366	400	400	406	406	450	450
1250	391	391	400	400	441	441	500	500
1600	421	421	550	550	491	491	500	500
2000	461	461	550	550	560	560	850	850
2500	511	511	550	550	630	630	850	850
3200	590	590	800	800	730	730	850	850
4000	670	670	800	800	810	810	850	850
5000	770	770	800	800	870	870	900	900

L edgewise elbow Fig 13.2

Rated current (A)	Copper busway size (mm)				Aluminium busway size (mm)			
	Minimum		Standard		Minimum		Standard	
	X	Y	X	Y	X	Y	X	Y
250	/	/	/	/	363	363	400	400
400	363	363	400	400	363	363	400	400
630	363	363	400	400	363	363	400	400
800	363	363	400	400	363	363	400	400
1000	363	363	400	400	363	363	400	400
1250	363	363	400	400	363	363	400	400
1600	363	363	400	400	363	363	400	400
2000	363	363	400	400	363	363	400	400
2500	363	363	400	400	363	363	400	400
3200	363	363	400	400	363	363	400	400
4000	363	363	400	400	363	363	400	400
5000	363	363	400	400	/	/	/	/

Dimension

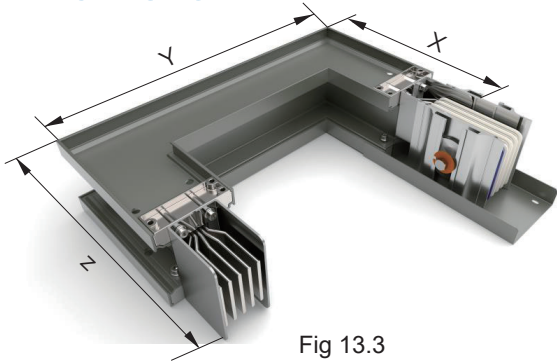

Fig 13.3

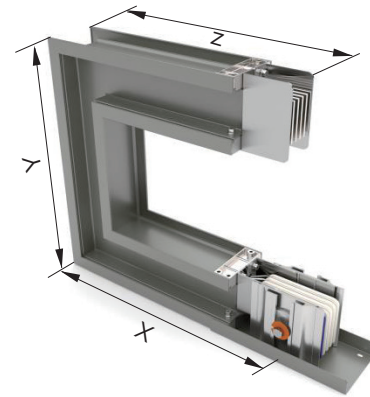

Fig 13.4

Flatwise U Fig 13.3

Rated current (A)	Copper busway size (mm)						Aluminium busway size (mm)					
	Minimum			Standard			Minimum			Standard		
	X	Y	Z	X	Y	Z	X	Y	Z	X	Y	Z
250	/	/	/	/	/	/	341	326	341	450	500	450
400	341	326	341	400	450	400	351	346	351	450	500	450
630	341	326	341	400	450	400	366	376	366	450	500	450
800	351	346	351	400	450	400	381	406	381	450	500	450
1000	366	376	366	400	450	400	406	456	406	450	500	450
1250	391	426	391	400	450	400	441	526	441	500	650	500
1600	421	486	421	550	700	550	491	626	491	500	650	500
2000	461	566	461	550	700	550	560	764	560	850	650	850
2500	511	666	511	550	700	550	630	904	630	850	1300	850
3200	590	824	590	800	1200	800	730	1104	730	850	1300	850
4000	670	984	670	800	1200	800	810	1264	810	850	1300	850
5000	770	1184	770	800	1200	800	/	/	/	/		

Edgewise U Fig 13.4

Rated current (A)	Copper busway size (mm)						Aluminium busway size (mm)					
	Minimum			Standard			Minimum			Standard		
	X	Y	Z	X	Y	Z	X	Y	Z	X	Y	Z
250	/	/	/	/	/	/	363	370	363	400	400	400
400	363	370	363	400	400	400	363	370	363	400	400	400
630	363	370	363	400	400	400	363	370	363	400	400	400
800	363	370	363	400	400	400	363	370	363	400	400	400
1000	363	370	363	400	400	400	363	370	363	400	400	400
1250	363	370	363	400	400	400	363	370	363	400	400	400
1600	363	370	363	400	400	400	363	370	363	400	400	400
2000	363	370	363	400	400	400	363	370	363	400	400	400
2500	363	370	363	400	400	400	363	370	363	400	400	400
3200	363	370	363	400	400	400	363	370	363	400	400	400
4000	363	370	363	400	400	400	363	370	363	400	400	400
5000	363	370	363	400	400	400	/	/	/	/	/	/

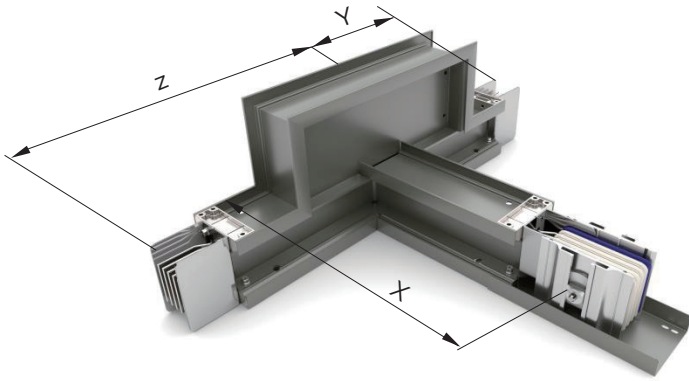

Fig 13.5

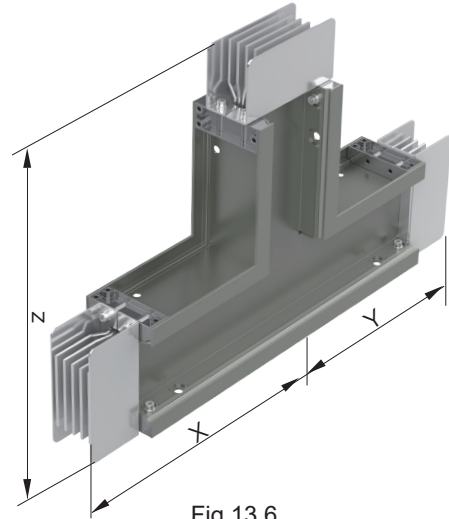

Fig 13.6

Flatwise Tee Fig 13.5

Rated current (A)	Copper busway size (mm)						Aluminium busway size (mm)					
	Minimum			Standard			Minimum			Standard		
	X	Y	Z	X	Y	Z	X	Y	Z	X	Y	Z
250	/	/	/	/	/	/	341	290	290	450	350	350
400	341	290	290	400	350	350	351	295	295	450	350	350
630	341	290	290	400	350	350	366	302	302	450	350	350
800	351	295	295	400	350	350	381	310	310	450	350	350
1000	366	302	302	400	350	350	406	322	322	450	350	350
1250	391	315	315	400	350	350	441	340	340	500	400	400
1600	421	330	330	550	400	400	491	365	365	500	400	400
2000	461	350	350	550	400	400	560	399	399	850	550	550
2500	511	375	375	550	400	400	630	434	434	850	550	550
3200	590	414	414	800	550	550	730	484	484	850	550	550
4000	670	454	454	800	550	550	810	524	524	850	550	550
5000	770	504	504	800	550	550	/	/	/	/	/	/

Edgewise Tee Fig 13.6

Rated current (A)	Copper busway size (mm)						Aluminium busway size (mm)					
	Minimum			Standard			Minimum			Standard		
	X	Y	Z	X	Y	Z	X	Y	Z	X	Y	Z
250	/	/	/	/	/	/	363	411	411	400	500	500
400	363	411	411	400	500	500	363	411	411	400	500	500
630	363	411	411	400	500	500	363	426	426	400	500	500
800	363	426	426	400	500	500	363	436	436	400	500	500
1000	363	436	436	400	500	500	363	461	461	400	500	500
1250	363	461	461	400	500	500	363	496	496	400	600	600
1600	363	496	496	400	600	600	363	531	531	400	600	600
2000	363	531	531	400	600	600	363	581	581	400	600	600
2500	363	581	581	400	600	600	363	660	660	400	900	900
3200	363	660	660	400	900	900	363	740	740	400	900	900
4000	363	740	740	400	900	900	363	840	840	400	900	900
5000	363	840	840	400	900	900	/	/	/	/	/	/

Dimension

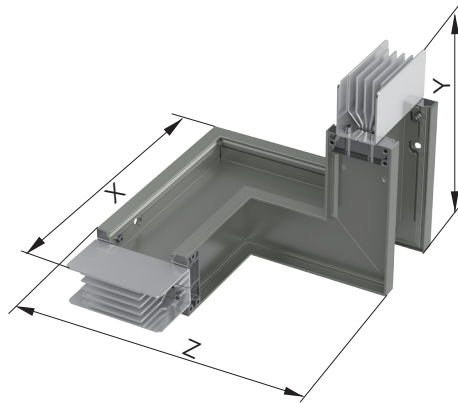

Fig 13.7

Combination Elbow Fig 13.7

Rated current (A)	Copper busway size (mm)						Aluminium busway size (mm)					
	Minimum			Standard			Minimum			Standard		
	X	Y	Z	X	Y	Z	X	Y	Z	X	Y	Z
250	/	/	/	/	/	/	341	348	363	450	450	400
400	341	348	363	400	400	400	351	358	363	450	450	400
630	341	348	363	400	400	400	366	373	363	450	450	400
800	351	358	363	400	400	400	381	388	363	450	450	400
1000	366	373	363	400	400	400	406	413	363	450	450	400
1250	391	398	363	400	400	400	441	448	363	500	500	400
1600	421	428	363	550	550	400	491	498	363	500	500	400
2000	461	468	363	550	550	400	560	567	363	850	850	400
2500	511	518	363	550	550	400	630	637	363	850	850	400
3200	590	597	363	800	800	400	730	737	363	850	850	400
4000	670	677	363	800	800	400	810	817	363	850	850	400
5000	770	777	363	800	800	400	/	/	/	/	/	/

Flanged end

Standard length: L=0.56m

Nonstandard length: L=0.56 ~ 2.00m

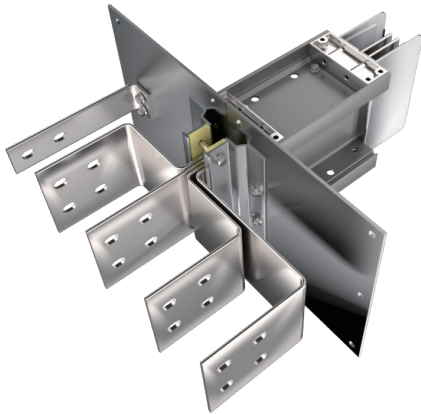

3P+100%N+50% integral housing as PE

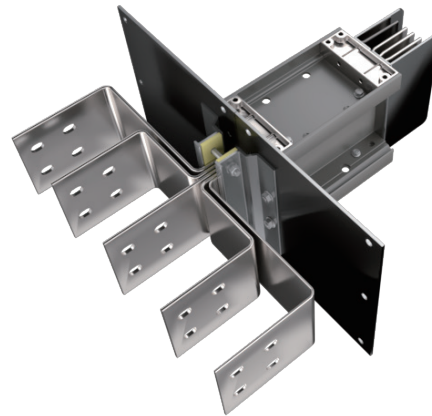

3P+100%N+50% internal bar as PE



Top view

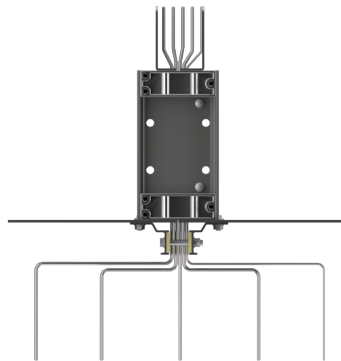

Section view



Section view

Flanged end and end tap box can be used in connection with any type of switchgear cabinets and transformers. Flanged end busbar spacing can be customized on specific application.

Note:

All the dimensions provided are for standard products. Please contact our engineers for customized dimensions.

Dimension

Flanged end cut out and drilling pattern

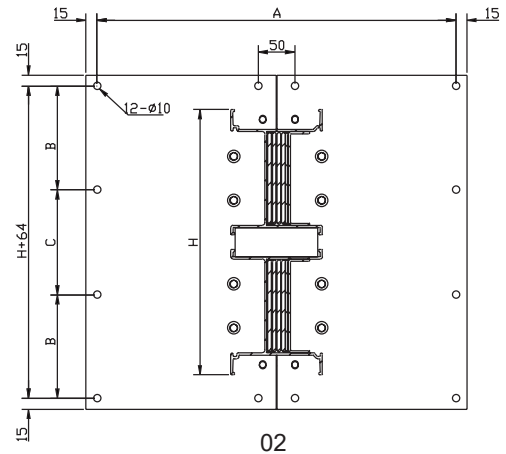
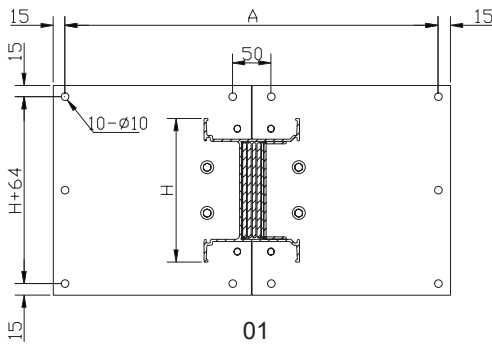

Alpha Power Cu

Alpha Power Al

Rated Current (A)	3L+N+PE Size (mm)				3L+N Size (mm)			Fig	Rated Current (A)	3L+N+PE Size (mm)				3L+N Size (mm)			Fig
	H	A	B	C	A	B	C			H	A	B	C	A	B	C	
400	103	490			370			01	250	103	490			370			01
630	103	490			370				400	113	490			370			
800	118	490			370				630	128	490			370			
1000	128	490			370				800	143	490			370			
1250	153	490			370				1000	168	490			370			
1600	188	490			370				1250	203	490			370			
2000	223	490			370				1600	253	490			370			
2500	273	490			370				2000	322	490	130	126	370	130	126	
3200	352	490	140	136	370	140	136		2500	392	490	150	156	370	150	156	
4000	432	490	165	166	370	165	166	4000	492	490	185	186	370	185	186	02	
5000	532	490	200	196	370	200	196	4000	572	490	210	216	370	210	216		

Dimension

Flanged end bar hole pattern

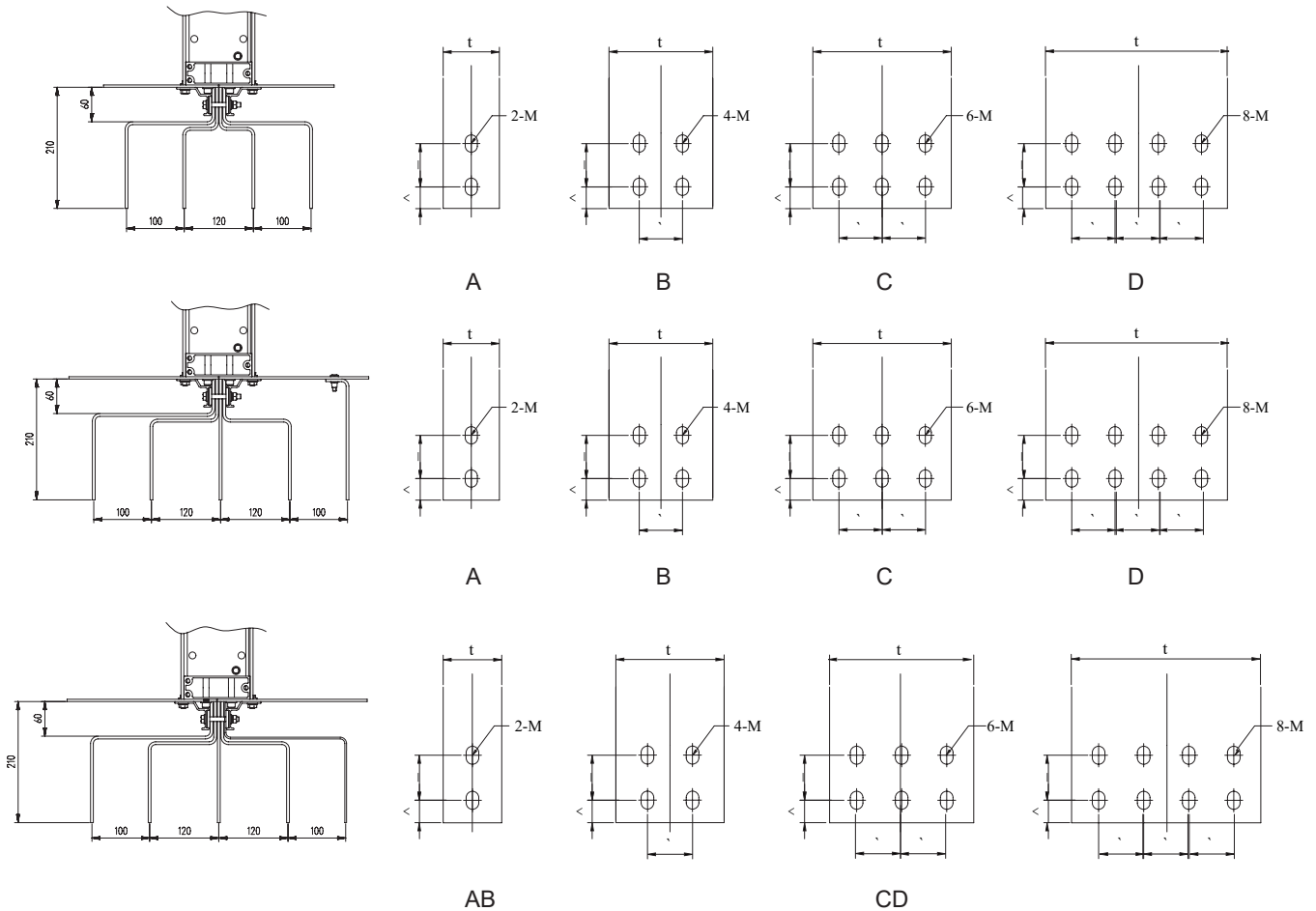

Copper conductor

Rated Current	A	B	C	M	Type
400	25	50		Φ12	A
630	25	50		Φ14×20	A
800	25	50		Φ14×20	A
1000	25	50		Φ14×20	A
1250	25	50	50	Φ14×20	B
1600	25	50	50	Φ14×20	B
2000	25	50	50	Φ14×20	C
2500	25	50	50	Φ14×20	D
3200	25	50	50	Φ14×20	B
4000	25	50	50	Φ14×20	C
5000	25	50	50	Φ14×20	D

Aluminum conductor

Rated Current	A	B	C	M	Type
250	25	50		Φ14×20	A
400	25	50		Φ14×20	A
630	25	50		Φ14×20	A
800	25	50		Φ14×20	A
1000	25	50	50	Φ14×20	B
1250	25	50	50	Φ14×20	C
1350	25	50	50	Φ14×20	C
1600	25	50	50	Φ14×20	C
2000	25	50	50	Φ14×20	D
2500	25	50	50	Φ14×20	C
3200	25	50	50	Φ14×20	C
4000	25	50	50	Φ14×20	D

Dimension

Expansion joint

Expansion length is the transition section compensating for thermal expansion, it is normally set each 60m in linear distance.

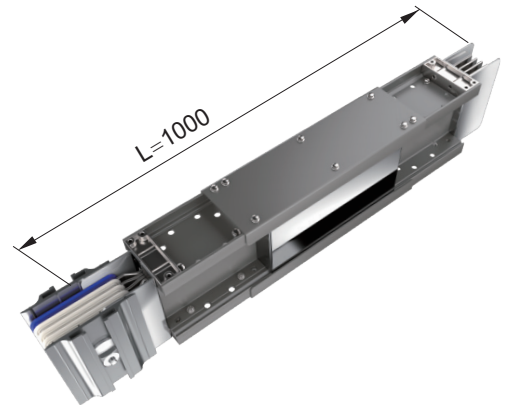

Reducer

This reducer section is used for reducing busbar size to the final load, it provides users with more economic power transmission and distribution method.

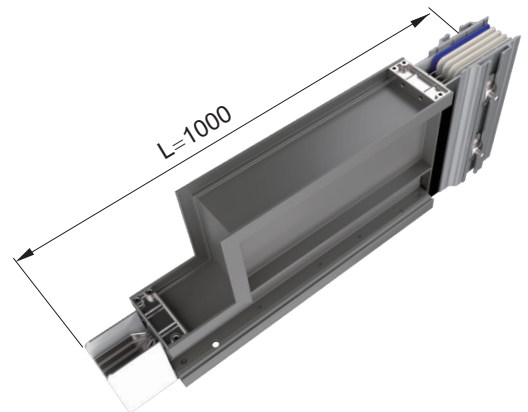

Transposition joint

Transposition section is the transition parts used for changing phase sequence of the busbar; its minimum size is 1500mm. The phase sequence of both sides has to be provided by the customer.

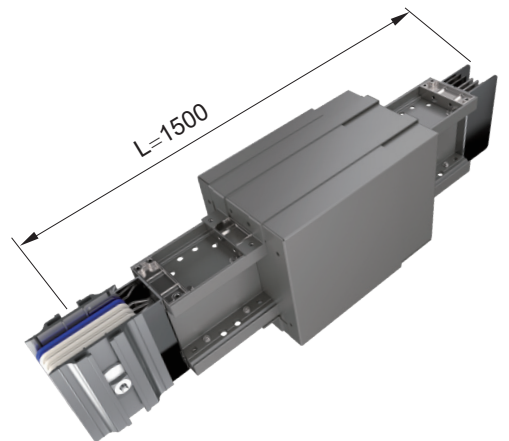

Terminal cover

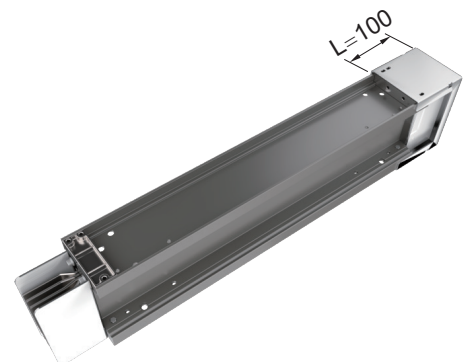

Tap-off units

Alpha Power tap-off units is adopted to apply electrical power directly to the load from the busway system. Fully considering customer's requirements, Alpha Power bus plug offers the options of circuit breaker or fuse.

Tap-off units with circuit breaker

- Circuit breaker protection can be available with a current range from 16A-1000A.
- Load protection in the box can be 3-Pole or 4-Pole circuit breakers, including accessories of breakers such as rotary handles, shunt release, thermal magnetic release and leakage-current protection module.

Tap-off units

- Tap-off units with fuses can be produced according to customer specifications.
- Unique fail-safe base pins

The plug-in boxes is equipped with a positioning device that prevents incorrect phase installations.

- Plug-in pins

All pins are silver-plated to improve the electrical conductivity.

Protection class up to IP54 with IEC 60529

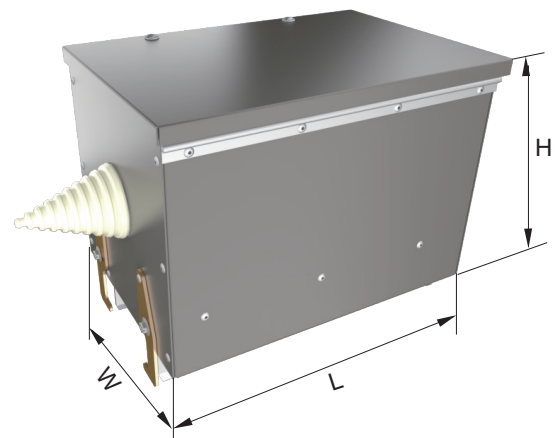
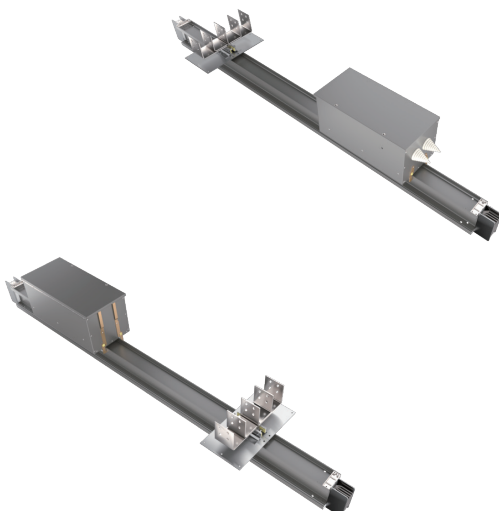

Plug-in box Dimensions (L×W×H)mm

- For tap-off box over 1000A, please contact the manufacturer.

Current ratings (A)	Plug-in box Dimensions			
	L(mm) Length	W(mm) Width	H(mm) Height	Minimum Height (mm)
100	360	250	255	250
160	400	250	255	250
250	520	270	275	270
400	650	310	315	310
630	800	340	345	340
800-1000	1200	420	355	350

Note:

Table 25-1 size is based on the size of common circuit breaker 3p/4p.

Dimension

End tap box

Alpha Power series busway system tap boxes are used where a run of busway is fed by cable. we offer standard size end tap box (1m×1m×1m) while we also supply with nonstandard box according to the on-site measurement.

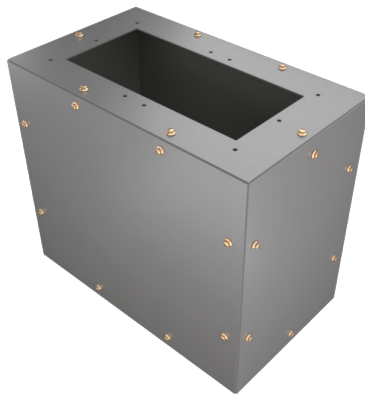

Flanged end with end tap box connection

The flange plate can be manufactured according to the size of the end tap box, it can be connected directly with end tap box.

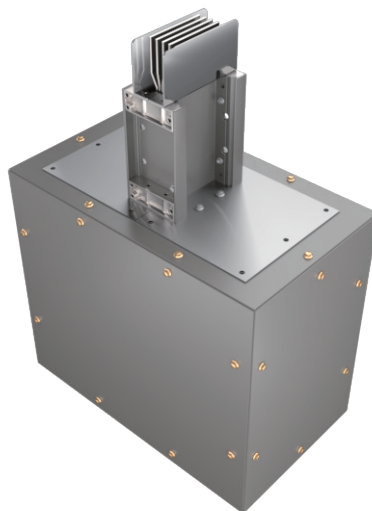

Installation

Protection Class

Alpha Power busway protection class can be up to IP66 according to different applications.

Notes:

IP40---"4" indicates that solid objects greater than 1mm in diameter will not penetrate the housing."0" denotes no protection.

IP42---"4" indicates that solid objects greater than 1mm in diameter will not penetrate the housing."2" denotes prevention of water dripping inside by an angle of up to 15°.

IP54---"5" for dust, "4" indicates splashes of water.

IP65---"6" for dust density, "5" indicates protection from water spray.

IP66---"6" for dust density, "6" for protection of stronger water spray

Minimum clearance required for installation

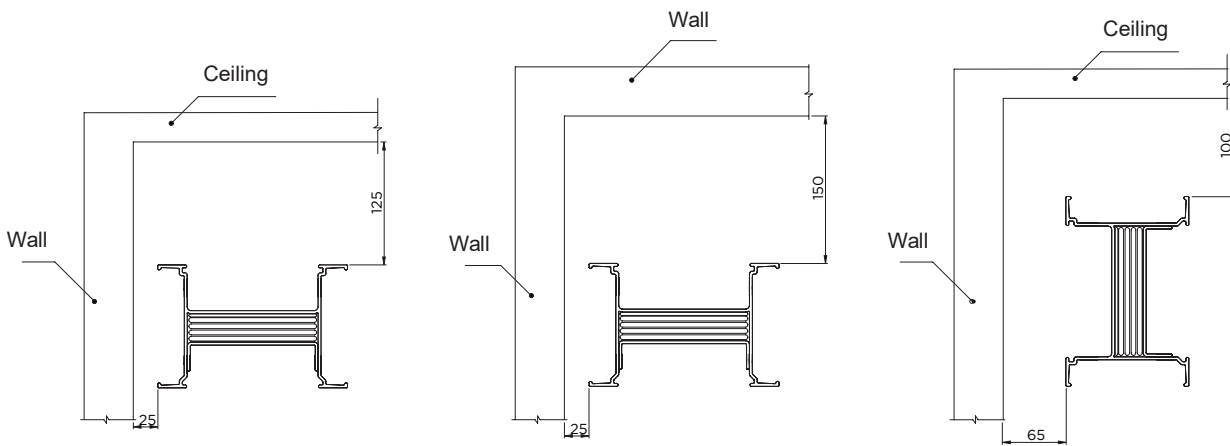

Minimum clearance required for plug-in box installation

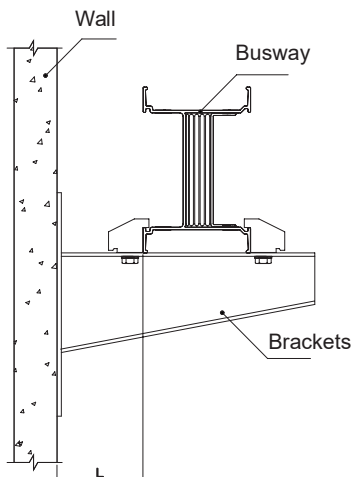

Current level for plug-in box	L(mm)
100	150
160	175
250	195
400	210
630	230
800	260
1000	300

Installation

Horizontal wall-through installation

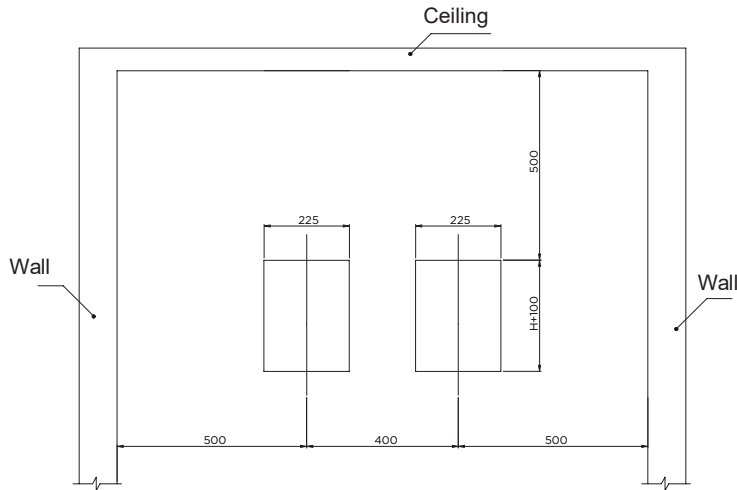

Horizontal installation-trapeze hangers Overhead Support

Holes should be first drilled in the floor so as to inlay steel expansion bolts (holes may also be drilled on site for flexible installation) or pre-bury steel U-channel for welding with hangers. The distance between two adjacent hangers shall not exceed 2m. Please specify any special requirements when placing your order.

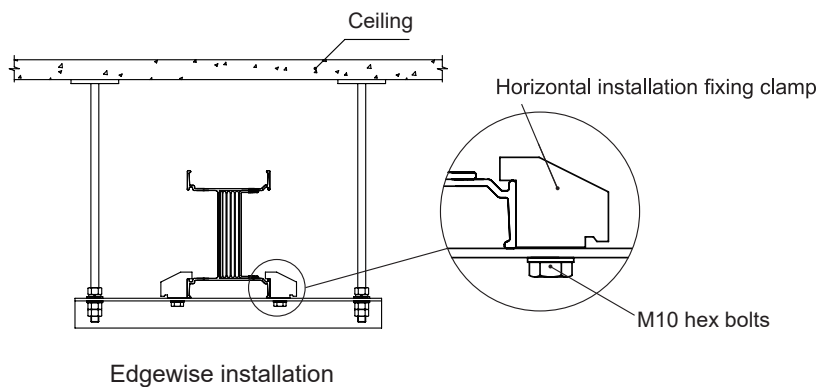
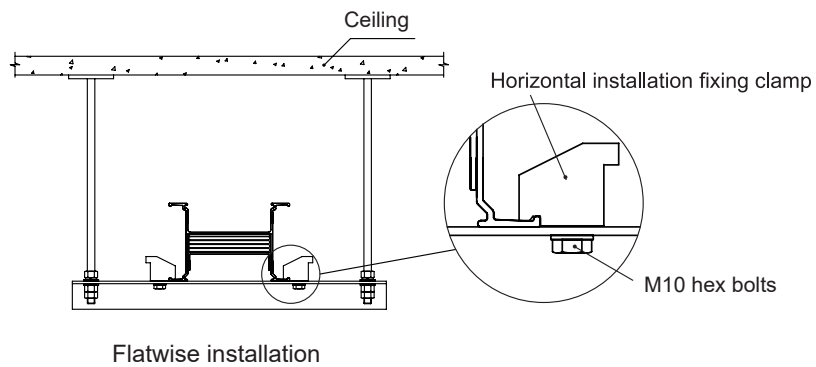

Horizontal installation-wall support

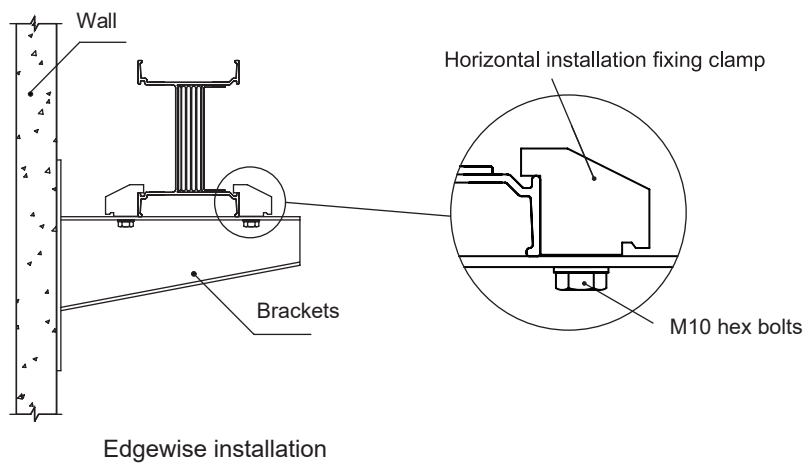
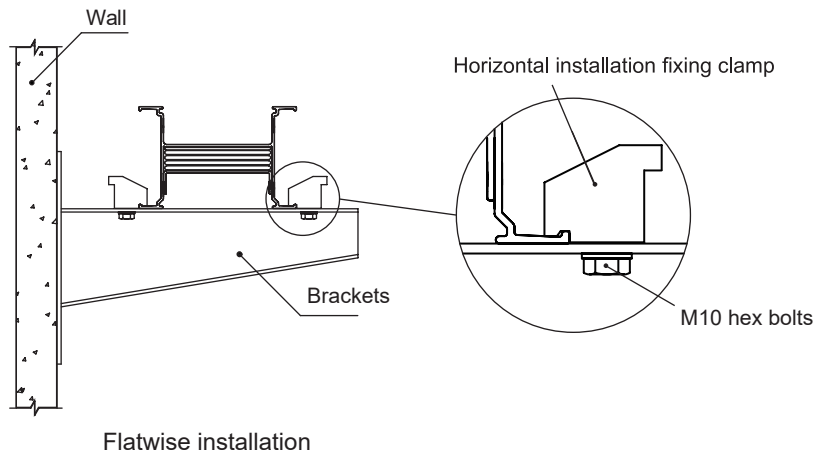

Installation

Vertical installation

When installing a vertical bus run, please refer to the figure for the dimension of the access holes. Please ensure that the spacing between every two runs of busway exceeds 350mm, especially if there are two or more vertical runs of busway installed in the same riser. Please refer to the figure below:

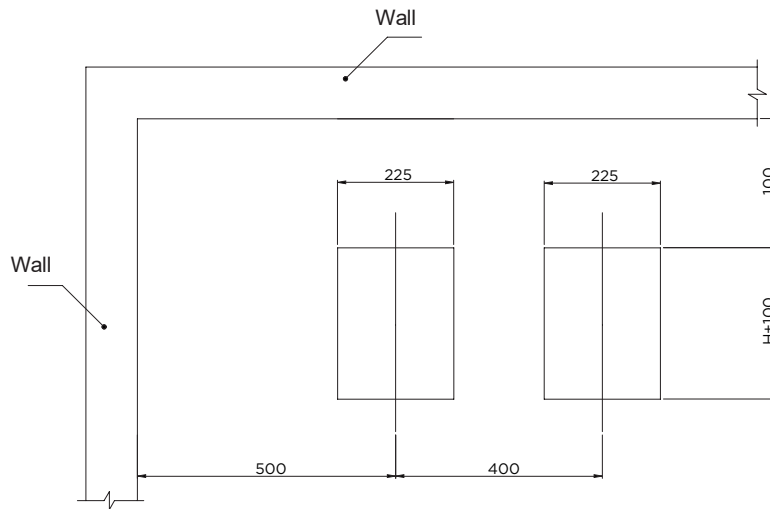

Installation for Vertical Spring Hanger

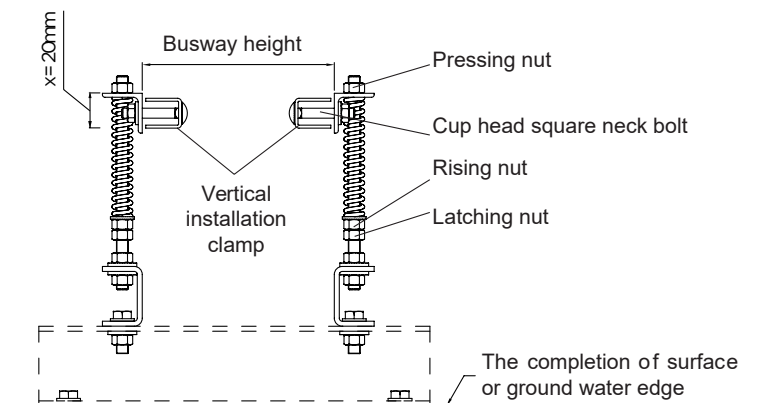
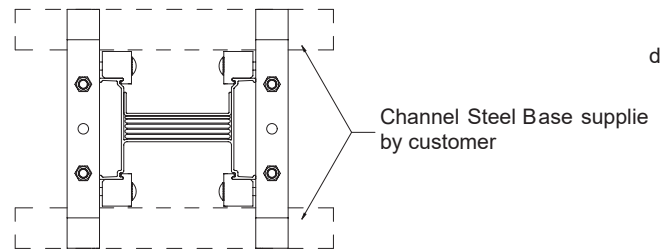
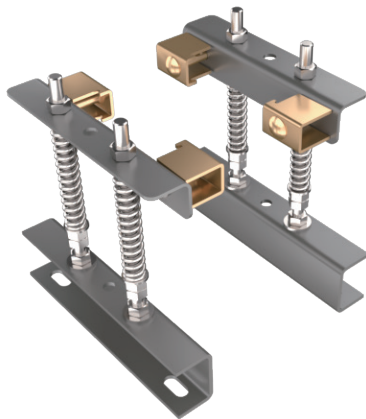

Installation Schematic Diagram

Installation for Vertical Fixed Hanger

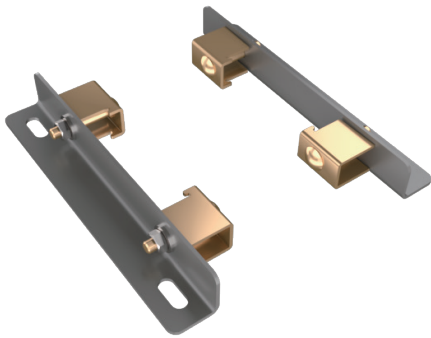

Vertical Fixed Hanger

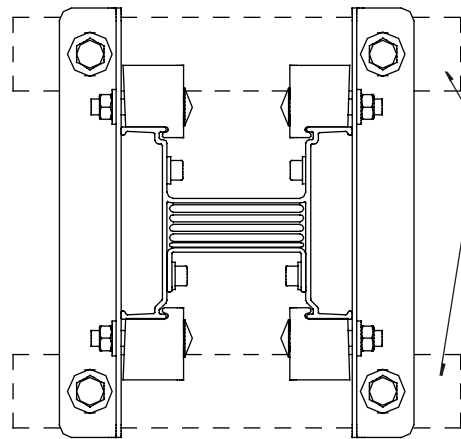

Channel Steel supplied by customer
Customer supply the fixed parts of channel steel to ground and hanger to channel steel

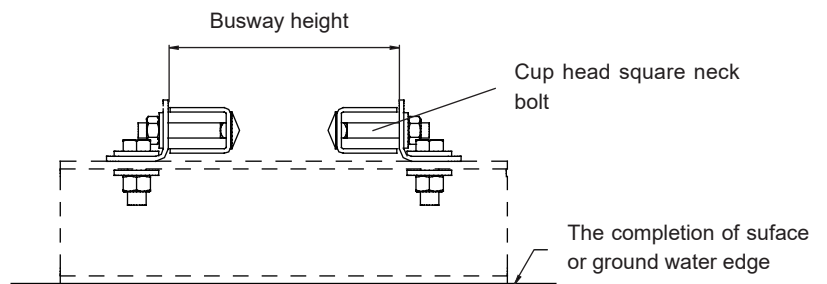

Installation Schematic Diagram

Product Code

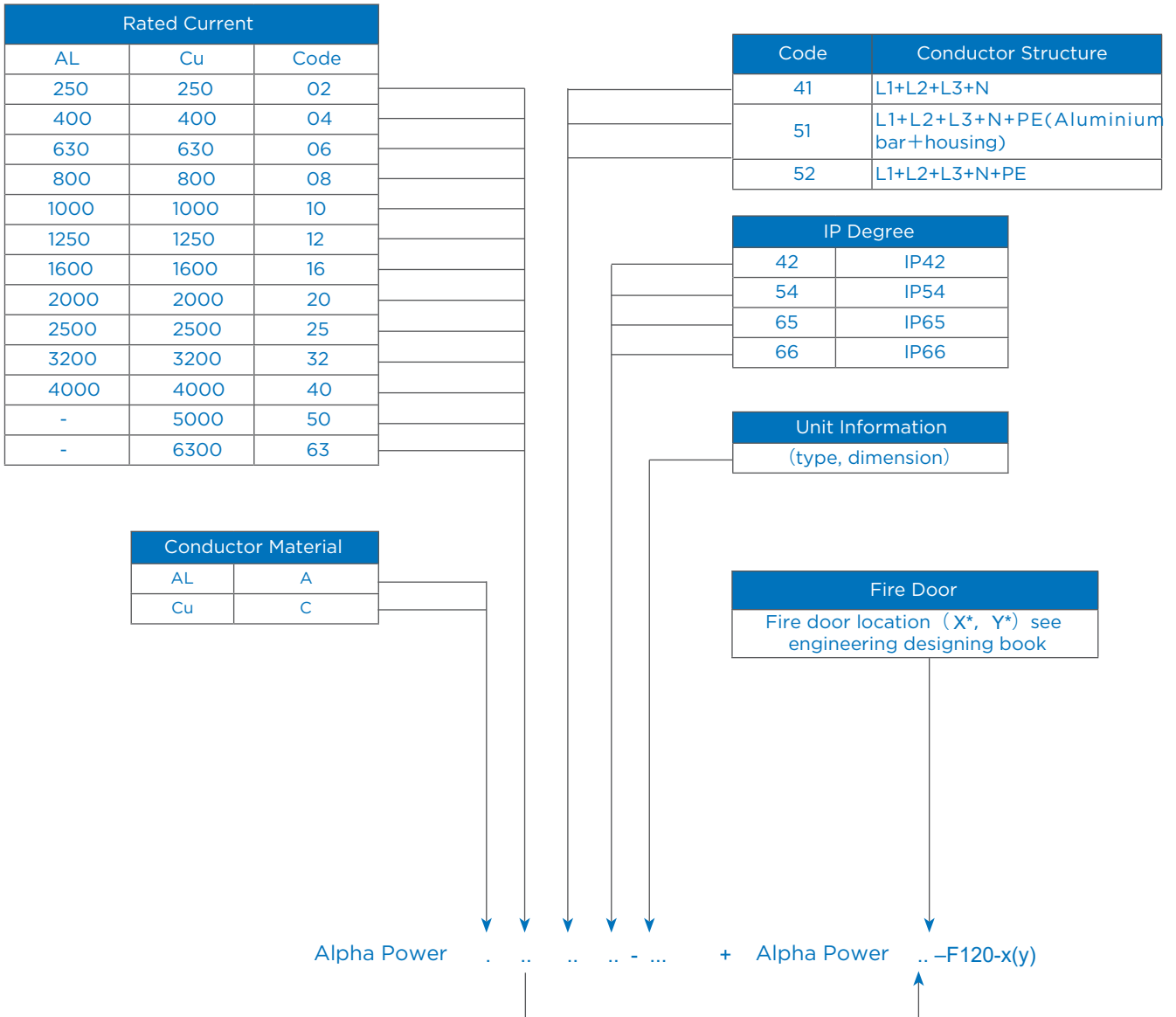

- Alpha Power:045265-3
- Model: Alpha Power Series
- 3P5W (L1, L2, L3, 100%N, 50% internal bar as grounding)
- IP degree: IP65
- The feeder length of the copper busway: 3m



WWW.westinghouselvmv.com
Email: info@westinghouselvmv.com