

Ammeter / Voltmeter Selector Switches



Specifications

Elements Of Contact Point	Ag & Cdo
Contact Rating	10Amp/ 600Vac
Dielectric Strength	2500Vac 1 min
Mlectrical Life	1,000,000 Cycles
Electrical Life	100,000 Cycles
Ambient temperature	Storage: -30~+70°C
	Operation : -20 ~ + 55°C

Operational Position

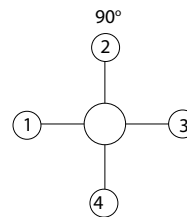
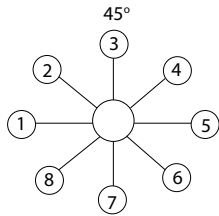

Name Plate

Voltmeter Switches	<p>Voltmeter</p> <p>OFF</p>	<p>Voltmeter</p> <p>RN</p>	<p>Voltmeter</p> <p>0</p>
Ammeter Switches	<p>Ammeter</p> <p>0</p>	<p>Ammeter</p> <p>0</p>	<p>Ammeter</p> <p>N</p>

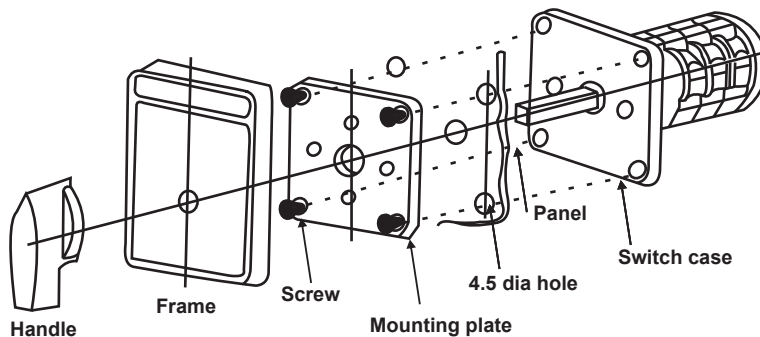

Ammeter / Voltmeter Selector Switches

Ammeter Switches 3 phase 3 Wire 2 CT



W604129

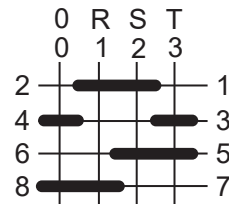

Contacts Overlap
3 2CT

Ammeter Switches 3 phase 4 Wire 3 CT



W604130

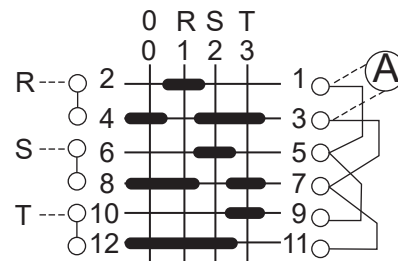

Contacts Overlap
3 ϕ 3CT

Voltmeter Switches 3 phase 3 Wire 3 CT



W604131

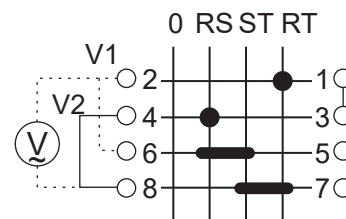

3 ϕ 3 Wire

Voltmeter Switches 3 phase 4 Wire



W604132

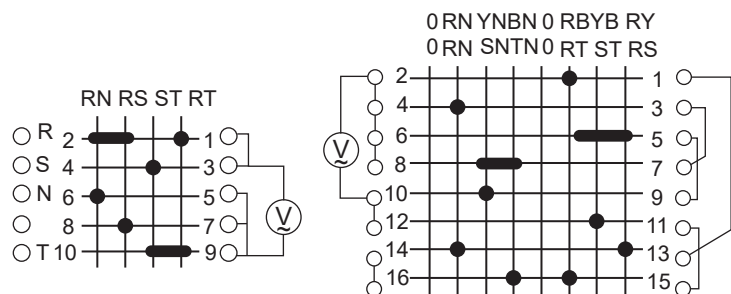

3 ϕ 4 Wire 7 Position